



# READY TO WORK

**15,500 LB. CAPACITY  
INTERNAL COMBUSTION  
PNEUMATIC TIRE LIFT TRUCK**



# REAL POWER, REAL PERFORMANCE

## Built For Your Business

The Cat® DP70N1 pneumatic tire lift truck offers proven reliability and durability, combined with the strength and stability you need to get the job done. Equipped with the high-performance Perkins™ 854F 3.4L engine, this lift truck offers increased fuel efficiency, reduced emissions and a lower overall operating cost.

### ADVANTAGES TO YOU:

- Controlled, yet powerful acceleration maximizes productivity.
- An 18% increase\* in fuel efficiency, resulting in a greater annual cost savings.
- 500-hour extended service intervals mean less downtime and maintenance costs.
- World-class service and support provided by the best dealer network in the industry.
- Emission levels well below Environmental Protection Agency (EPA) Tier 4 Final requirements.

### KEY APPLICATIONS:

- Lumber
- Steel and pipe
- Fabricated metals
- Concrete, stone, clay and glass
- Industrial machinery and equipment



**Fuel-efficient Perkins®  
854F 3.4L diesel engine  
EPA Tier 4 Final-compliant**

\*Based on preliminary test results; levels may vary depending on application.



**Visibility from front to back**  
Narrow mast channels and a low profile counterweight enhance visibility

**High performance**  
Low-speed torque offers controlled, yet powerful acceleration which promotes maximum productivity

**Solid steel frame**  
For added strength

**Smooth ride**  
Full-floating drive axle features two bearings on a fixed spindle for added stability and sturdiness

**Strength and durability**  
One-piece steer axle reduces stress on the chassis, allowing the truck to perform in a variety of environments



# DESIGNED FOR UPTIME



## Made To Perform

With a lift capacity of 15,500 pounds and a powerfully efficient, turbocharged four-cylinder engine, the Cat DP70N1 lift truck raises the bar on performance – delivering powerful acceleration and reduced fuel costs for a better bottom line.

### HIGH-PERFORMANCE PERKINS TIER 4 FINAL ENGINE

Building only the best in industrial engines, Perkins has spent a vast amount of time and resources on engine development for increased productivity and lower overall operating costs. The Perkins 854F four-cylinder engine is able to provide the same productivity with a fraction of the fuel and a fraction of the cost of operation.

#### Benefits:

- Performs with 18% more fuel efficiency than previous models, resulting in greater annual savings\*.
- Fuel saver mode lowers fuel consumption even further (by up to 14%) while maintaining up to 95% of overall productivity\*\*.
- Low-speed torque offers controlled, yet powerful acceleration for maximum productivity throughout the shift.
- A compact turbocharger delivers six-cylinder power in a four-cylinder package, resulting in rapid response and a better driving experience for your operators.
- Meets EPA Tier 4 Final standards.

\* Based on preliminary test results; levels will vary depending on application.

\*\* Fuel consumption levels may vary based on application.

# POWER THAT DOESN'T COMPROMISE

## TIER 4 FINAL: THE RIGHT TECHNOLOGY FOR MAXIMUM PERFORMANCE

### **Proven Approach:**

Features a compact Diesel Oxidation Catalyst (DOC) and Selective Catalytic Reduction (SCR) aftertreatment solution that meets or exceeds U.S. EPA Tier 4 Final standards. This technology is designed to be maintenance-free for the life of the engine.

### **Cat® Lift Trucks Advantage:**

- Optimized DOC/SCR emissions solutions
- Fuel efficient
- Field-proven performance
- Increased uptime
- Fully supported by your local Cat lift truck dealer

### **Engine Protection:**

Regulated by the Vehicle Control Module, the Engine Protection System keeps the lift truck running at desirable levels while helping to reduce the risk of damage. If vital fluids become critically low, or fluid temperatures are too high, RPM levels are automatically lowered and the operator is notified by a light on the dash display.



**Easy Maintenance:**

Simplified maintenance means less downtime and more time on the job.

- Easy-to-remove floor panel and steel side covers; no tools required
- Greater uptime and lower planned maintenance costs
- Easy access to all major components
- Less time consuming daily inspections
- Extended 500-hour service intervals





## OPTIONAL CAB

Three cab options allow you to customize the lift truck for your business:

- Front windshield with wiper
- Top panel with tempered glass for optimal viewing
- Back panel with fold-out glass panel
- Steel doors
- Heater
- Fan



## OPTIONAL CONTROLS

Optional fingertip controls are integrated into the armrest for easy access and control.

- Provides control of the lift truck's hydraulic functions with minimal effort
- Reduces operator fatigue

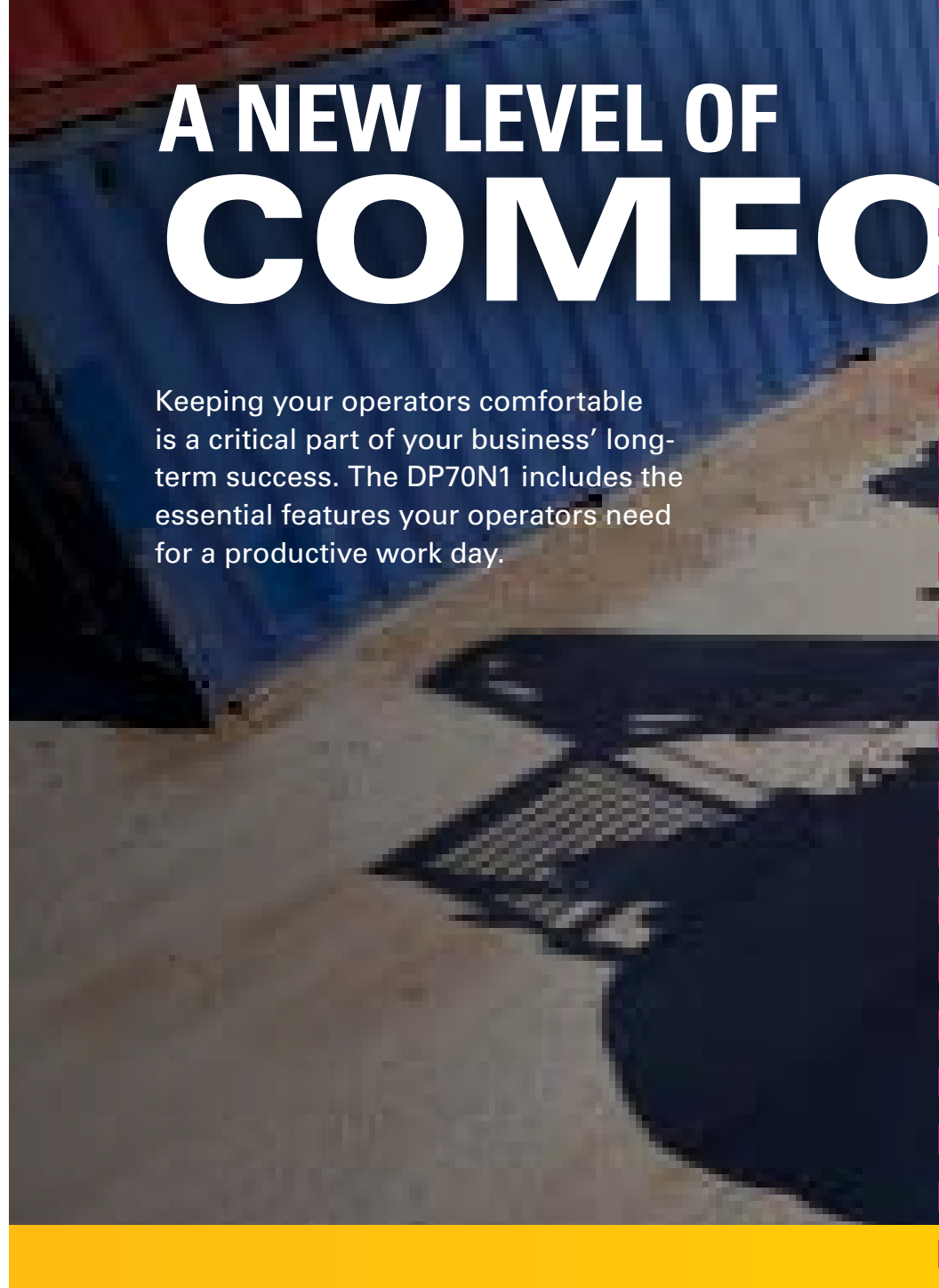

# A NEW LEVEL OF COMFO

Keeping your operators comfortable is a critical part of your business' long-term success. The DP70N1 includes the essential features your operators need for a productive work day.

## COMFORTABLE RIDE

The full-suspension standard vinyl seat can be adjusted for operator comfort.

- **Front and back adjustment** – slides up to 6.5 inches to accommodate operators of various heights
- **Suspension adjustment** – adds support in the seat based on the weight of the operator
- **Lumbar support adjustment** – supports the operator's lower back
- **Fold down pin** – allows the seat to easily move for access to the engine hood

## LESS NOISE, LESS VIBRATION

Minimizing noise and vibration levels will help keep the operator comfortable throughout the shift.

Less vibration and noise is achieved through the use of:

- Rubber mounted components
- Fully-insulated engine hood
- Helical transmission gears
- Closed wheel wells



PORT



## MORE FEATURES FOR MORE CONTROL

- **Standard orange seat belt** – allows managers to easily see when operators are properly wearing their seat belt.
- **Electronic direction control** – allows the operator to shift between forward and reverse travel without losing contact with the steering wheel. The result is smooth acceleration and direction changes up to 2.5 mph.
- **Hydrostatic steering** – minimizes the effort needed to smoothly steer the lift truck, providing more operator control and maneuverability.
- **Tilt steering column with mechanical quick return** – equipped with a memory function designed to adjust and lock and return to its preset position.
- **Pneumatic tires** – provide traction and a comfortable ride in rugged terrain. The standard dual drive tires offer added stability while handling loads up to 15,500 lbs.

# TAKING CONTROL OF YOUR WORKDAY

## More Awareness

Moving heavy loads in the toughest terrain requires a high level of awareness and the ultimate in control. The Cat DP70N1 features all-around visibility and essential indicators to keep your operators alert and confident.

### TOTAL CONTROL

- **Premium LCD/LED Display** – the easy-to-read display with at-a-glance indicators keeps the operator aware of the truck's performance at all times. Features like speed, travel direction and maintenance requirements are easily visible throughout operation.
- **Engine Protection System** – this system is designed to keep the lift truck running at peak performance. Display-based indicators immediately notify the operator when vital fluids are low or engine maintenance is required, resulting in greater uptime while helping to prevent more costly maintenance needs later.
- **Electronic Backup Alarm** – the alarm sounds anytime the truck is in reverse, alerting pedestrians and other operators working nearby.
- **Ground Speed Control** – software and sensors limit the maximum operating travel speed of the truck while maintaining optimal acceleration and performance. See your local Cat lift truck dealer for flexibility in adjusting the speed in applications requiring stricter policies.
- **LED Lights** – these work lights have a longer life, minimize glare and are cooler than traditional bulbs – all features that lower the cost of ownership while improving operator productivity.

### VISIBILITY – FROM FRONT TO BACK

The DP70N1 provides all-around visibility.

- Slim profile mast and open overhead guard design
- Lower profile counterweight enhances visibility when working in reverse

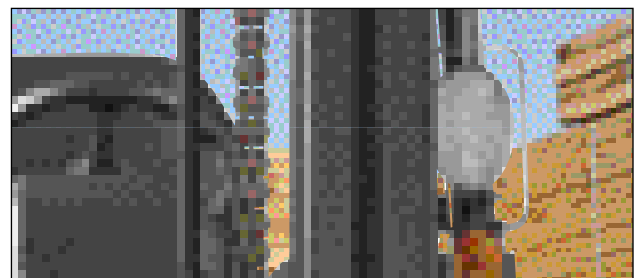

A yellow CAT forklift is shown in a warehouse setting, carrying a large stack of white pallets. The background is filled with numerous other stacks of pallets, creating a sense of a busy industrial environment. The forklift is positioned in the lower right quadrant of the frame, moving towards the left. The lighting is bright, highlighting the yellow of the forklift and the white of the pallets.

## ADDED AWARENESS

With these standard features:

- Highly-visible orange seat belt
- Anti-slip step plate
- 18-inch elongated grab bar
- Electronic backup alarm

## PRESENCE DETECTION SYSTEM (PDS)

The Presence Detection System (PDS) activates whenever the operator does not fasten the seat belt during operation or leaves the normal operating position without activating the parking brake. This integral computer-based feedback system uses both audible and visual indicators to alert the operator and increase operator awareness.

### Key features:

- When the operator is not in the normal operating position, the PDS electronically discontinues powered-travel movement and activation of load-handling functions.
- When an operator is in the normal operating position, but the seat belt is not buckled, an audible warning will sound and a visible indicator will appear, alerting the operator.



Local service and support



Genuine OEM parts



Custom financing packages

# MORE CONFIDENCE



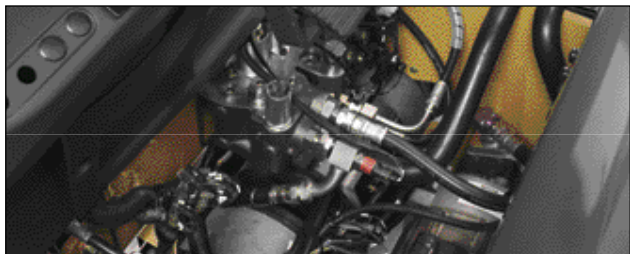

Factory warranty for added protection

## Local Support You Can Count On

A Cat lift truck purchase connects you to a variety of material handling solutions, including world-class service and support from your local, trusted dealer. With trained service technicians, a diverse parts inventory and a broad selection of service options, your local dealer can help you lower costs, enhance productivity and more efficiently manage your business.

### FINANCING MADE SIMPLE

Financing your next Cat lift truck is easy with our wide range of flexible leasing and purchasing options. Whether you want to finance or lease, your local Cat lift truck dealer can help customize a package for your business.

### WHEN EVERY PART COUNTS

When buying from your local Cat lift truck dealer, you can rest assured that your genuine OEM parts are manufactured to meet original equipment criteria. Additionally, all Cat lift trucks OEM parts come with a six-month, unlimited-hours warranty.

When speed is critical, our Parts Fast Or Parts Free Guarantee\* ensures next-business-day delivery of all Cat lift trucks parts, or they're free, including freight. If your part doesn't come in by the next business day, we pay for it.

### STANDING BEHIND OUR PRODUCTS

We deliver peace of mind by helping your lift trucks stay on the job. Every new Cat lift truck is covered by a 1-year / 2,000-hours warranty that includes parts and labor, as well as components and systems. With our standard 2-year / 4,000-hours extended powertrain warranty, you'll have the confidence that only comes from owning a Cat lift truck.

\* At dealer's location.

† Programs may be subject to change without notice and may vary by region. Please ask your local Cat lift truck dealer for complete terms and conditions.

## Specifications

Characteristics				DP70N1	
1	Capacity at rated load center	lb	kg	15,500	7,000
2	Capacity at load center – distance	in	mm	24	600
3	Power – electric, diesel, gasoline or LP gas	diesel			
4	Tire type – cushion or pneumatic	pneumatic			
5	Wheels (x=driven) – number front / rear	4x / 2			
Dimensions				DP70N1	
6	Maximum fork height (top of fork) <sup>1)</sup>	in	mm	120.5	3,060
7	Free fork height <sup>1)</sup>	in	mm	7.9	200
8	Forks – thickness x length x width <sup>1)</sup>	in	mm	2.4 x 48 x 5.9	60 x 1,220 x 150
9	Fork spacing – out-to-out minimum / maximum	in	mm	11.8 / 63.0	300 / 1,600
10	Tilt – forward / backward	deg		6° / 12°	
11	Length to fork face	in	mm	141	3,580
12	Width – with dual drive tires	in	mm	85.4	2,170
13	Height – with lowered mast <sup>1)</sup>	in	mm	101.5	2,570
14	Seat height to SIP	in	mm	62.7	1,592
15	Height – to top of overhead guard	in	mm	103	2,610
16	Height – with extended mast <sup>1)</sup>	in	mm	168.5	4,277
17	Minimum outside turning radius	in	mm	130	3,310
18	Load moment constant	in	mm	23.0	585
19	Minimum aisle – 90° stack – zero clearance without a load	in	mm	153	3,895
Performance				DP70N1	
20	Travel speed – loaded / empty	mph	km/h	15.5 / 18.0	25.0 / 29.0
21	Lift speed – loaded / empty	fpm	m/s	92.5 / 96.1	0.47 / 0.49
22	Lowering speed – loaded / empty	fpm	m/s	98.4 / 98.4	0.50 / 0.50
23	Drawbar pull – loaded at 1 mph (1.6 km)	lb	N	8,760	38,950
24	Drawbar pull – loaded maximum	lb	N	11,890	52,880
25	Gradeability – loaded at 1 mph (1.6 km)	%		25	
26	Gradeability – maximum loaded	%		35	
Weight				DP70N1	
27	Empty	lb	kg	20,770	9,420
28	Axle load – with rated load front / rear	lb	kg	32,690 / 3,580	14,800 / 1,620
29	Axle load – without load front / rear	lb	kg	9,240 / 11,530	4,190 / 5,230
Chassis				DP70N1	
30	Tire size – front, standard duals	in		8.25-15-12PR	
31	Tire size – rear tires	in		8.25-15-12PR	
32	Wheelbase	in	mm	90.6	2,300
33	Tread width – front, standard duals	in	mm	65.0	1,650
34	Tread width – rear tires	in	mm	65.0	1,650
35	Ground clearance – at lowest point at mast	in	mm	6.7	170
36	Ground clearance – at center of wheelbase	in	mm	10.4	263
37	Service brake	hydraulic with vacuum boost			
38	Parking brake	hand, mechanical			
Powertrain				DP70N1	
39	Engine model	Perkins 854F			
40	Engine – continuous output S.A.E. gross	HP	kW	100.6	75
41		at rpm		2,480	
42	Engine – maximum torque S.A.E. gross	lb-ft	N-m	214	290
43		at rpm		1,600	
44	Cylinder / displacement	cu in	L	4 / 2075	4 / 3.4
45	Transmission – type	powershift			
46	Transmission – number of speeds forward / reverse	2 / 2			
47	Battery	volts		12	
48	Relief pressure for attachments	psi	bar	2,770	191
49	Noise level – mean value at operator's ear Leq	dB(A)		86.5	

1) heights with shaft type forks on standard two-stage mast. Optional hook type forks will change dimensions slightly.

NOTE: Dimensions represent maximum battery size, not compartment size. These specifications assume the use of drive axles, tires and tilt angles specified. Any modification to specifications, or any other combination of specifications made after the shipment of the truck, requires prior written approval from Mitsubishi Caterpillar Forklift America Inc. (MCF). (See ANSI/ITSDF B56.1.) Also be advised that overall operating visibility may be affected by the mast configuration and mast options of your lift truck. Therefore, you may need to add ancillary [auxiliary] devices or modify your operating practices. Consult your dealer for further information.

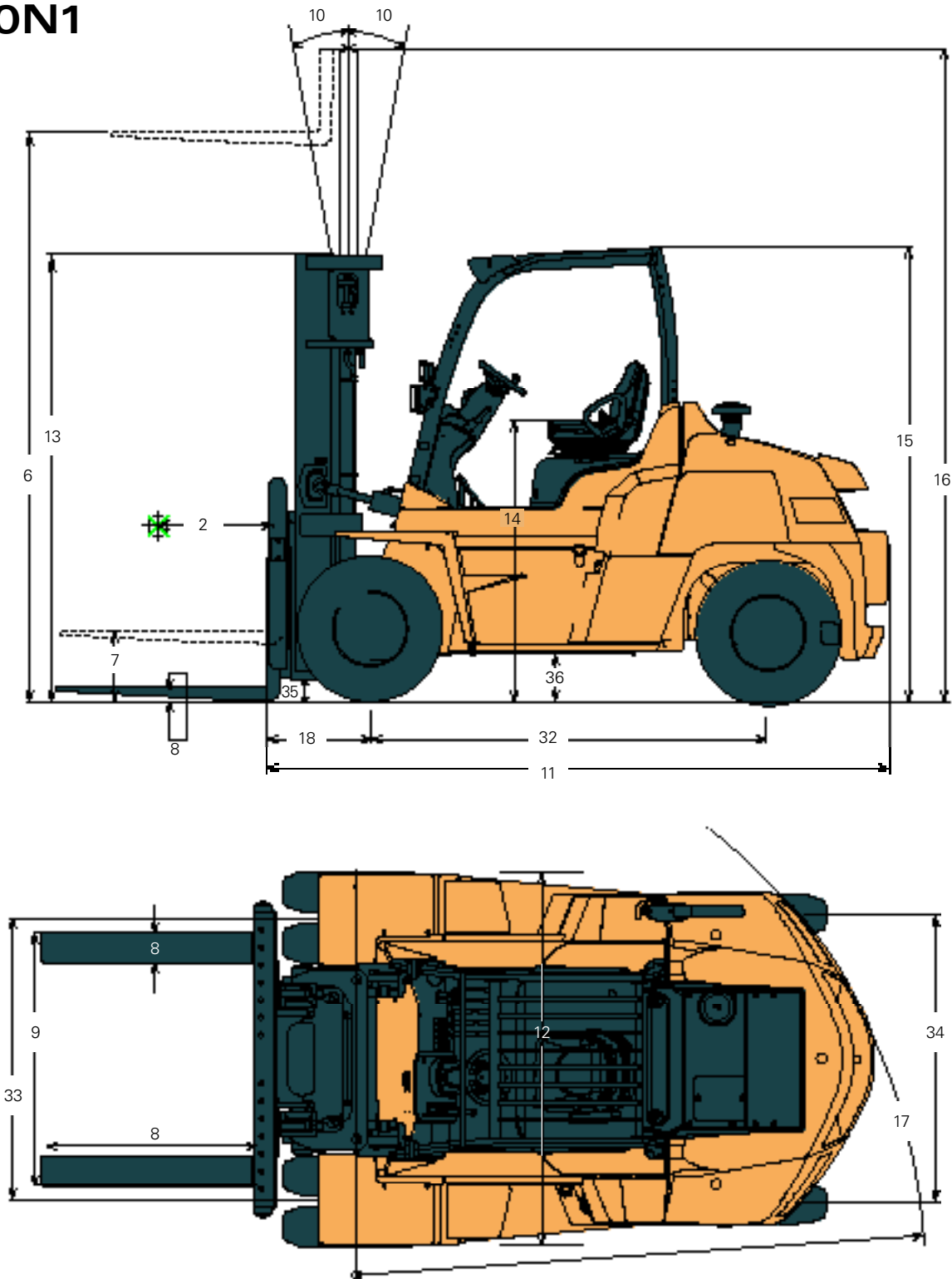

## Safety Standards

These trucks meet American National Standards Institute/ Industrial Truck Standards Development Foundation, ANSI/ITSDF B56.1. Users should be aware of, and adhere to, applicable codes and regulations regarding operator training, use, operation and maintenance of powered industrial trucks, including:

- ANSI/ITSDF B56.1.
- NFPA 505, fire safety standard for powered industrial trucks – type designations, areas of use, maintenance, and operation.
- Occupational Safety and Health Administration (OSHA) regulations that may apply.

Specifications, equipment, technical data, photos and illustrations based on information at time of printing and subject to change without notice. Some products may be shown with optional equipment.





**Your Cat lift truck dealer** can provide additional options and features to specialize your lift truck for your unique application. Operator training and custom financing programs are also available to help find the right fit for your business.

Helping move businesses forward – that's how we're built.

**BUILT FOR IT.**

**1-800-CAT-LIFT | [www.mcfa.com/cat](http://www.mcfa.com/cat)**

© 2018 MCFA. All Rights Reserved. CAT, CATERPILLAR, BUILT FOR IT, their respective logos, "CaterpillarYellow," the "Power Edge" trade dress as well as corporate and product identity used herein, are trademarks of Caterpillar and may not be used without permission. All registered trademarks are the property of their respective owners.

Some products may be shown with optional equipment.

CECV0202

04/18

